

## Installation Setup and Operating Instructions Thermostatic Water Mixing Valve Systems G3600 & G3650

**IMPORTANT!** Provide valve serial number (stamped on cover of valve) when ordering parts.

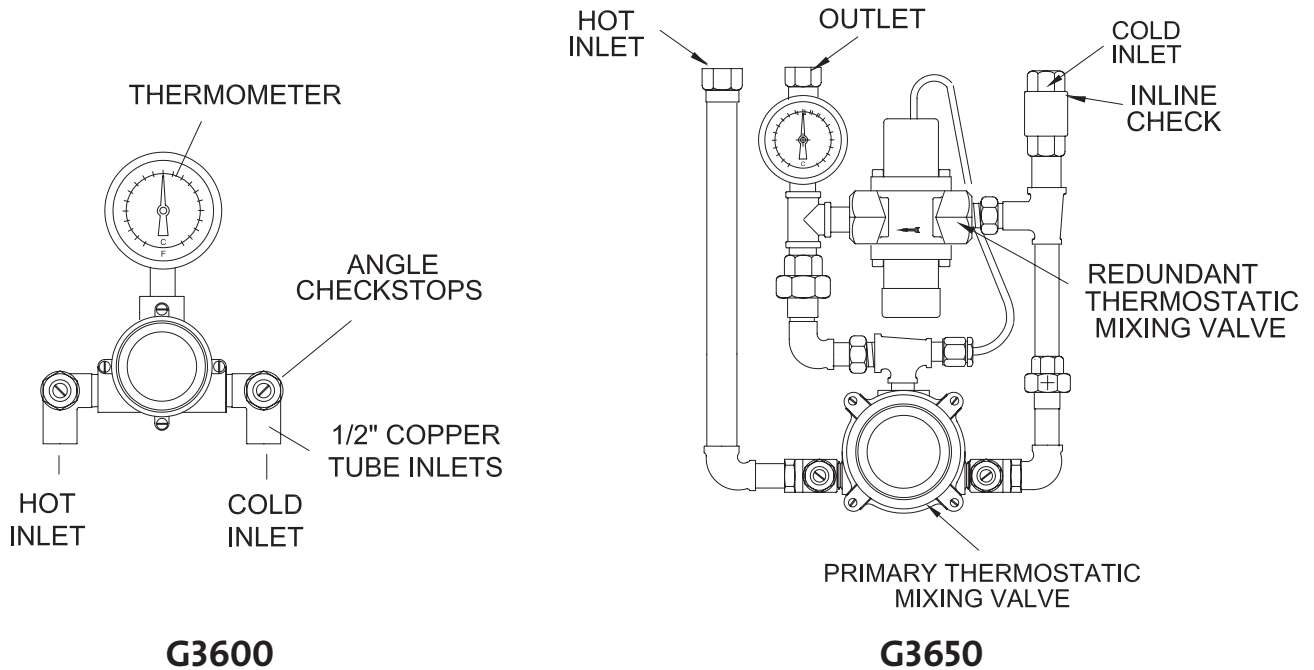

### Installation

1. Valve should be installed at a location where it can easily be cleaned, adjusted or repaired.
2. The inlets are clearly marked on the valve body casting. Connect the hot water into the inlet marked "HOT" and cold water into the inlet marked "COLD."
3. The checkstops furnished must be installed on both supply lines as shown above.
4. Use solder or pipe cement sparingly. Supply pipes should be flushed before the valve is connected. Flush outlet pipe and valve as soon as it is connected.

Maximum Operating Pressure 125PSI (860 KPA) for Hot and Cold Water.

*Note: It may be necessary to recirculate the tempered water to the face/eyewash should the piping be exposed to excessive hot or cold conditions. Consult factory for proper piping.*



**CAUTION**

**IMPORTANT! THESE SYSTEMS ARE DESIGNED TO PROVIDE MIXED WATER FROM 60 TO 90°F (15 TO 32°C) FOR EMERGENCY SHOWER APPLICATIONS ONLY. CALL GUARDIAN EQUIPMENT FOR SYSTEMS DESIGNED TO OPERATE AT TEMPERATURES OUTSIDE OF THIS RANGE.**

**NOTE: THIS IS A CONTROL SYSTEM WHICH MUST BE CLEANED AND MAINTAINED ON A REGULAR BASIS (SEE MAINTENANCE GUIDE AND RECORD MGRG-1000).**

## Adjustment And Service

Guardian equipment Thermostatic Water Mixing Valves are simple in design and may be easily cleaned, adjusted and repaired. If the installation is accessible, servicing may be completed without disconnecting the valve.

*Note: Thermostatic Water Mixing Valves are REGULATING mechanisms, which must be regularly maintained to provide best performance. Frequency of cleaning depends on quality of local water conditions and usage. (See Maintenance Guide and Record MGRG-1000 and ANSI Z358.1).*

### To reset adjustable high temperature limit stop:

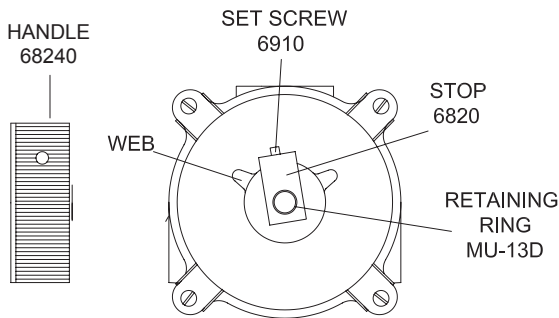

1. Remove 68240 handle, MU-13D retaining ring and loosen 6910 set screw, and remove 6820 stop.
2. Turn emergency fixture on.
3. Replace handle on stem and turn stem until desired maximum temperature is reached.
4. Replace stop so it rests against the web on the LEFT side of the cover.
5. Set operating temperature, tighten 6910 set screw and reassemble.

## ! WARNING !

**THIS THERMOSTATIC MIXING VALVE HAS AN ADJUSTABLE HIGH TEMPERATURE LIMIT STOP WHICH MUST BE CHECKED. IF TEMPERATURE IS TOO HIGH, THE INSTALLER MUST RESET THIS STOP IMMEDIATELY. ALWAYS CHECK THE TEMPERATURE OF THE MIXED WATER WHEN THE LEVER HANDLE IS TURNED TO FULL HOT. EXCESSIVELY HOT WATER IS DANGEROUS AND MAY CAUSE SCALDING!**

**THE HIGH TEMPERATURE LIMIT STOP IS FACTORY SET AT APPROXIMATELY 90°F (32°C) WITH AN INCOMING HOT WATER SUPPLY TEMPERATURE OF 135°F (57°C). IF THE INCOMING HOT WATER ON THE JOB IS HIGHER THAN 135°F, THE VALVE WHEN TURNED TO FULL HOT WILL DELIVER WATER IN EXCESS OF 90°F (32°C) AND THE HIGH TEMPERATURE LIMIT STOP MUST BE RESET BY THE INSTALLER.**

## Troubleshooting Table

Symptom	Component Type	Part No.	Description
Leak between valve cover and base.	Packings and Gaskets	6806	Cover Gasket
Leak at pointer rod.	Packings and Gaskets	MU-5A	O-Ring
Valve outlet temperature cannot be adjusted or will not mix consistently.	Port Sleeve Assembly	TAG-1M or Kit #R/TA/M	Port Sleeve Assembly Rebuild Kit
After cleaning or replacing port sleeve assembly, valve will not hold temperature.	Thermostat Group	6810 or Kit #R/TA/M	Thermostat Group or Rebuild Kit
Hot water bypass into cold line.	Check Stops	Kit #4/LVC Kit #B	for G3600 for G3650
Supplies cannot be shut off completely.	Check Stops		
Leak at checkstop bonnet.	Check Stops		

SEE PAGE 5 FOR COMPLETE PARTS BREAKDOWN AND PARTS KITS. If installed on a circulated hot water system, make certain the valve is piped according to Guardian Equipment Required Methods of Piping (see page 3).

**NOTE: THIS IS A CONTROL SYSTEM WHICH MUST BE CLEANED AND MAINTAINED ON A REGULAR BASIS (SEE MAINTENANCE GUIDE AND RECORD MGRG-1000).**

## Required Method of Piping G3600 & G3650 Valves

METHOD #1: Required when hot water is to be circulated to a thermostatic mixing valve which is a substantial distance from the hot water source.

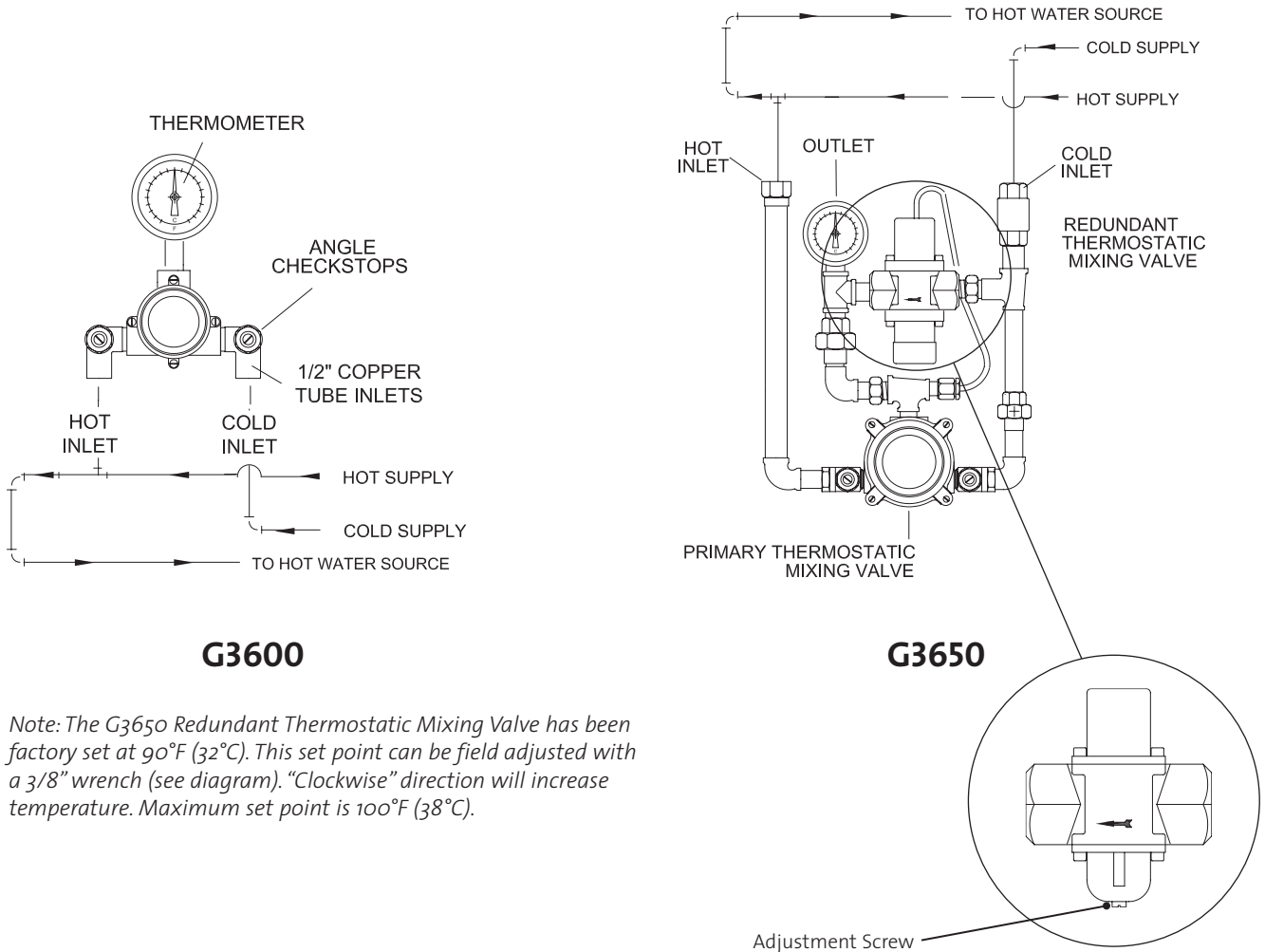

*Note: The G3650 Redundant Thermostatic Mixing Valve has been factory set at 90°F (32°C). This set point can be field adjusted with a 3/8" wrench (see diagram). "Clockwise" direction will increase temperature. Maximum set point is 100°F (38°C).*

This unit must be cycled each time the emergency equipment is checked. See ANSI Z358.1, Maintenance and Training section:

- Cycle redundant thermostat valve by, limit stop (see page 2) and setting the primary thermostatic mixing valve to full hot. (G3600 only)
- Open eye wash and check to be sure outlet temperature does not climb above 90°F (32°C).
- Turn primary thermostatic valve to full cold and wait ten seconds.
- Turn primary thermostatic valve to full hot and wait ten seconds.
- Check to be sure outlet temperature does not climb above 90°F (32°C).
- Turn primary thermostatic mixing valve to full cold and wait ten seconds.
- Set primary thermostatic mixing valve to the desired temperature, adjust limit stop (see page 2) and close eye/face wash.

**NOTE: THIS IS A CONTROL SYSTEM WHICH MUST BE CLEANED AND MAINTAINED ON A REGULAR BASIS (SEE MAINTENANCE GUIDE AND RECORD MGRG-1000).**

## Instructions for Dismantling Valve

Turn off hot and cold supplies to this valve. Remove four cover screws MU-2C, lift off cover and thermostat group 6810 (fig. 1). After installing new parts, it will be necessary to reset Pointer to obtain correct temperature range from Cold to Hot. See page 2 instructions "TO RESET ADJUSTABLE HIGH TEMPERATURE LIMIT STOP."

### To Clean Port Sleeve Assembly:

To clean port sleeve assembly TAG-1M (fig. 2.): Remove base stud TA-5. Back off port sleeve nut 3402 as far as it will go into base. Slide TAG-1M port sleeve assembly toward port sleeve nut and lift out of valve base. Clean part TAG-1M with a soft cloth; DO NOT use abrasives such as emery cloth or sandpaper. After cleaning, wash parts in clean water and reassemble in valve base. When reassembling port sleeve assembly BE SURE TO INSTALL WITH SHORT SLOT END IN BASE AND LONG SLOT END AT PORT SLEEVE NUT. Locate one set of port slots facing directly toward front of the valve. Tighten port sleeve nut 3402 just enough to hold port sleeve in place, (do not cramp or distort port sleeve by exerting excess size pressure when tightening port sleeve nut).

### To Clean Thermostat Group:

To clean thermostat group 6810 (DWG 1.), remove handle 68240 by loosening lock screw and pull off. Remove stop retaining ring MU-13D and stop 6820. Remove thermostat group by pushing rod through cover. **BE CAREFUL NOT TO PULL COILS OUT OF SHAPE.** If deposit has collected on thermostat coil, clean it off with a brush in cleaning solution and wash well before reassembly. Cleaning solution should be non-corrosive and grit free. To reassemble: be sure, port sleeve assembly is in place and is working freely from side to side. Reinstall base stud TA-5, then place thermostat group 6810 on base stud and **BE SURE DRIVING BALL ON PORT SLEEVE ASSEMBLY TAG-1M IS INSERTED IN HOLE ON LOWER COIL BRACKET (DWG 3.)** Move thermostat back and forth to be sure all parts are free. Replace cover on valve base, install the four cover screws, and turn on hot and cold water supplies. See instructions below "To Reset High Temperature Limit Stop" to properly reset limit stop.

After installation, adjustment, and cleaning, always check the temperature of the valve when turned to full HOT per the warning on the front page, using a thermometer. Also check and if necessary adjust the temperature of the hot water source. **EXCESSIVELY HOT WATER (OVER 90°F) IS DANGEROUS AND MAY CAUSE SCALDING!!**

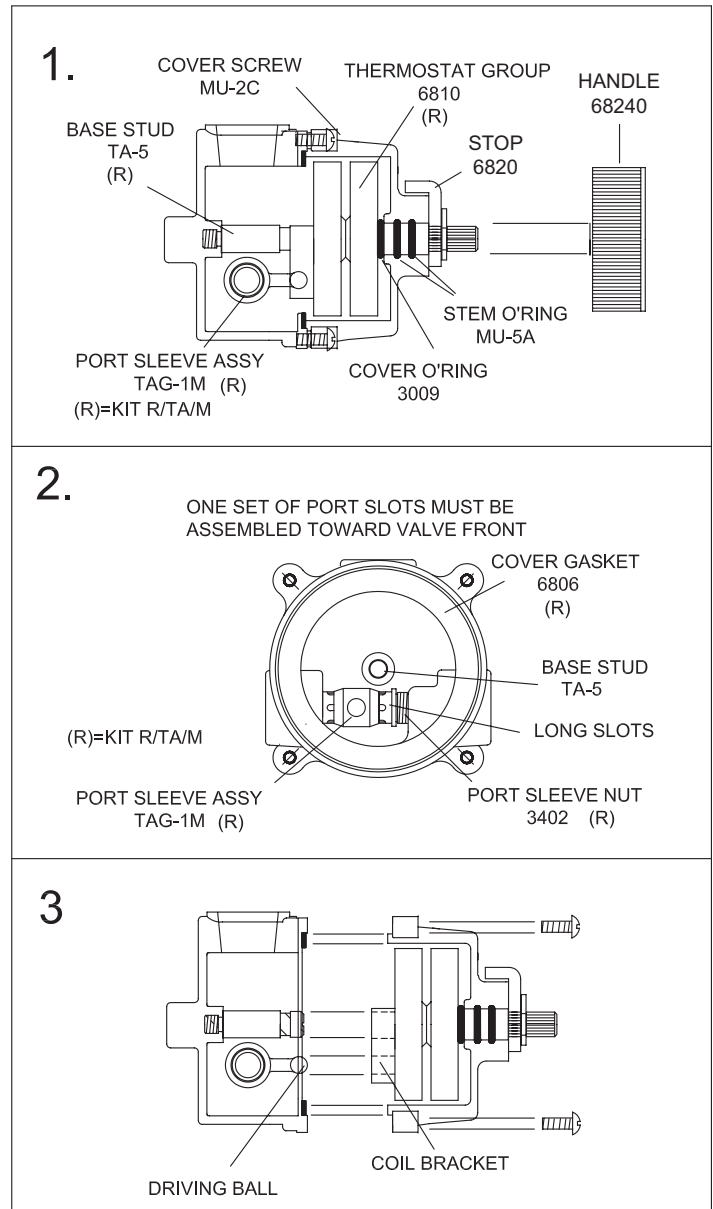

**NOTE: THIS IS A CONTROL SYSTEM WHICH MUST BE CLEANED AND MAINTAINED ON A REGULAR BASIS (SEE MAINTENANCE GUIDE AND RECORD MGRG-1000).**

## G3600 Valve Parts

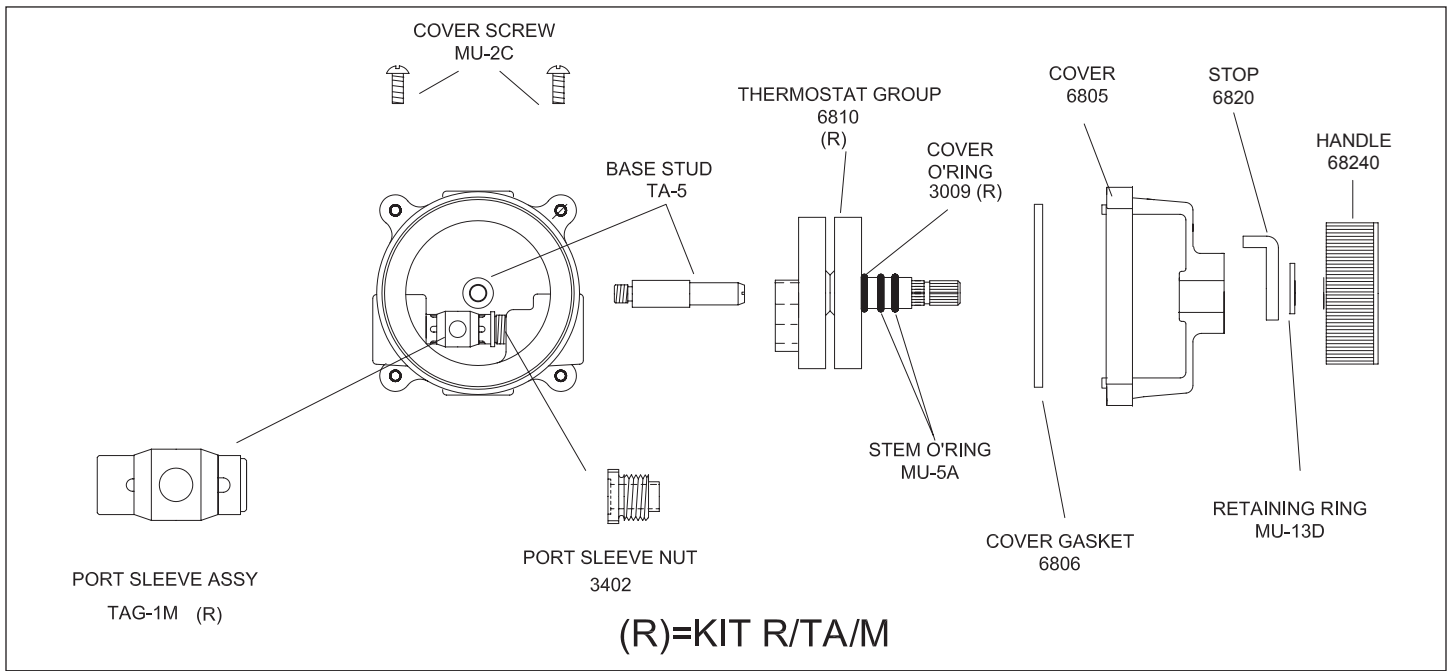

## Checkstop Parts

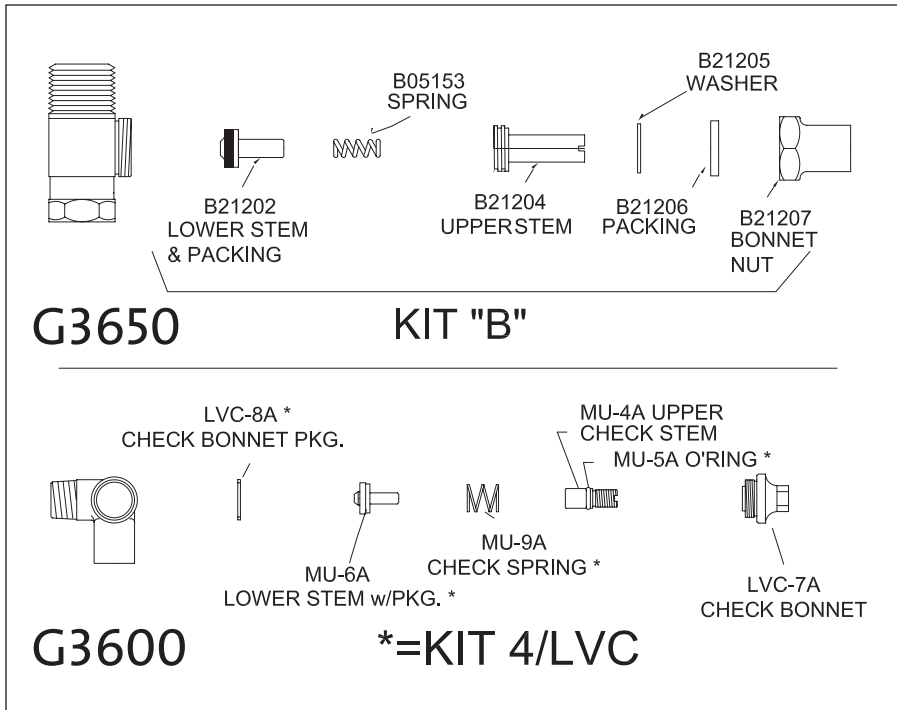

## Repair Kit

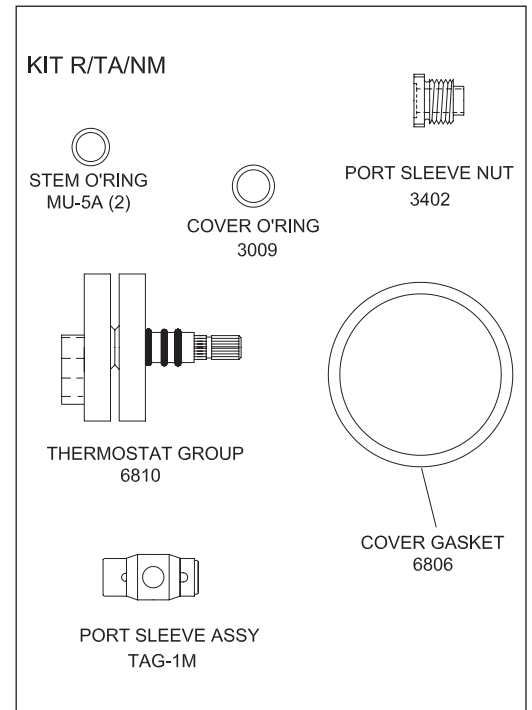

## Lock-Type Pointer

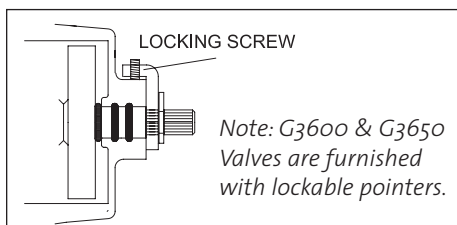

Note: after installing new parts it will be necessary to reset the adjustable high temperature limit stop, (see page 2).

**NOTE: THIS IS A CONTROL SYSTEM WHICH MUST BE CLEANED AND MAINTAINED ON A REGULAR BASIS (SEE MAINTENANCE GUIDE AND RECORD MGRG-1000).**

## Flow Capacities

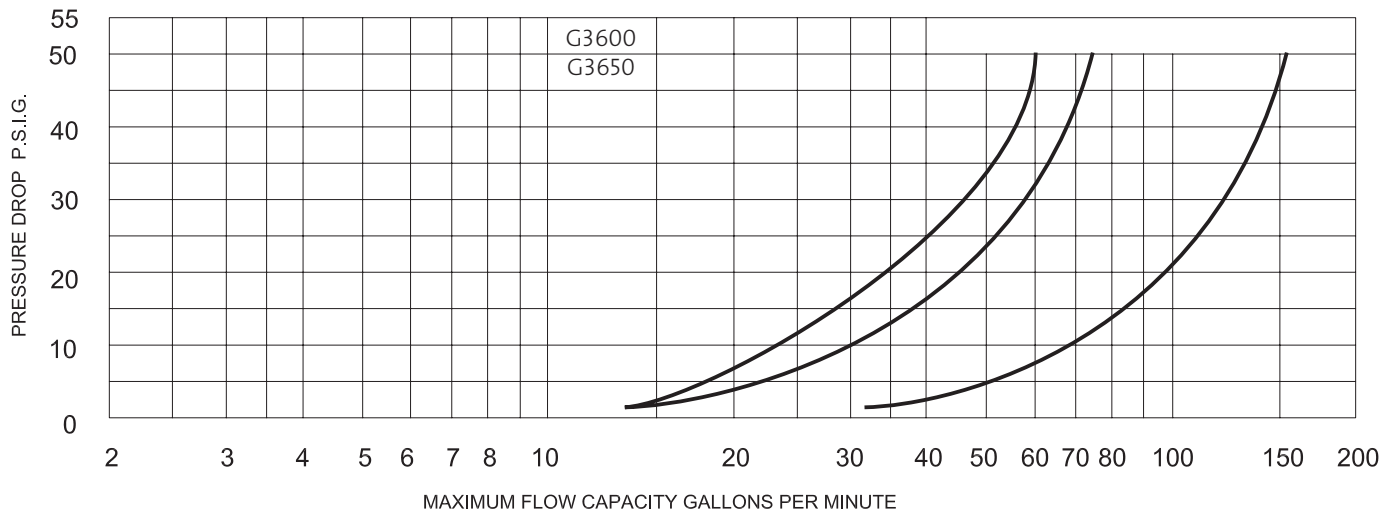

### CAUTION!

ALL THERMOSTATIC WATER MIXING VALVES HAVE LIMITATIONS. THEY WILL NOT PROVIDE THE DESIRED ACCURACY OUTSIDE OF THEIR FLOW CAPACITY RANGE. CONSULT THE CAPACITY CHART AND DO NOT OVERSIZE. MINIMUM FLOW MUST BE NO LESS THAN SHOWN BELOW.

### IMPORTANT!

THESE SYSTEMS ARE DESIGNED TO PROVIDE MIXED WATER FROM 60 TO 90°F (15 TO 32°C) FOR FACE/EYEWASH APPLICATIONS ONLY. CALL GUARDIAN EQUIPMENT FOR SYSTEMS DESIGNED TO OPERATE AT TEMPERATURES OUTSIDE OF THIS RANGE.

MODEL	IN**	OUT**	MINIMUM FLOW (GPM) L/MIN	INTERNAL COLD WATER BYPASS MINIMUM	SYSTEM PRESSURE DROP									
					5	10	15	20	25	30	35	40	45	PSI
G3600	1/2"	1/2"	2	4	2.5	4	5	6	7	8	8.5	9.5	10	GPM
			7.6	15	9.5	15	19	23	27	30	32	36	38	L/MIN
MAXIMUM FLOW CAPACITY														
**G3600 HAS 1/2" NOMINAL SWEAT CONNECTIONS. G3650 HAS 3/4" NPT THREADED CONNECTIONS.														

## Limited Warranty

Guardian Equipment warrants the original purchaser that products manufactured by them, (not by others), will be free from defects in materials and workmanship under normal conditions of use. When properly installed and maintained in accordance with Guardian Equipment's instructions, for a period of one year from date of shipment. During this period the Guardian Equipment will at its option repair or replace any product, or part thereof, which shall be returned, freight prepaid, to the Guardian Equipment factory and determined by Guardian Equipment to be defective in materials or workmanship. There are no warranties, express or implied, which extend beyond the description contained herein. There are no implied warranties of merchantability or of fitness for a particular purpose. In no event will Guardian Equipment be liable for labor or incidental or consequential damages. Any alteration or improper installation or use of the product will void this limited warranty.

**NOTE: THIS IS A CONTROL SYSTEM WHICH MUST BE CLEANED AND MAINTAINED ON A REGULAR BASIS (SEE MAINTENANCE GUIDE AND RECORD MGRG-1000).**