



### □ **GBF1724** Barrier-Free WideArea™ Eye/Face Wash, Wall Mounted



**Application:** Barrier-Free WideArea™ eye/face wash for wall mounting. Bowl is lowered and extended to permit access by wheelchair user. Profile of unit is “flattened” to comply with maximum height and knee clearance requirements.

**ADA Compliance:** When installed at recommended mounting height, unit complies with ADA requirements for accessibility by handicapped persons (maximum height and reach, minimum knee clearance and distance from obstructions).

**Spray Head Assembly:** Four GS-Plus™ spray heads. Each head has a “flip top” dust cover, internal flow control and filter to remove impurities from the water flow.

**Valve:** 1/2" IPS chrome plated brass stay-open ball valve. Valve is US-made with chrome plated brass ball and PTFE seals.

**Bowl:** 11-1/8" diameter stainless steel.

**Mounting:** Welded stainless steel wall bracket.

**Supply:** 1/2" NPT female inlet.

**Waste:** 1-1/2" OD chrome plated brass tailpiece.

**Sign:** ANSI-compliant identification sign.

**Quality Assurance:** Unit is completely assembled and water tested prior to shipment.

### Available Options

- **G6020** Thermostatic mixing valve precisely blends hot and cold water to deliver tepid water as required by ANSI Z358.1-2014. Refer to “Thermostatic Mixing Valves” section for complete technical and product selection information.
- **BC** Stainless steel cover for eye/face wash bowl.
- **HS** Auxiliary hand-held drench hose for rinsing eyes, face or body.
- **T** Chrome plated brass tailpiece and trap with 1-1/2" IPS waste connection.





### GBF1724 Barrier-Free WideArea™ Eye/Face Wash, Wall Mounted

MOUNTING PATTERN

SECTION A-A

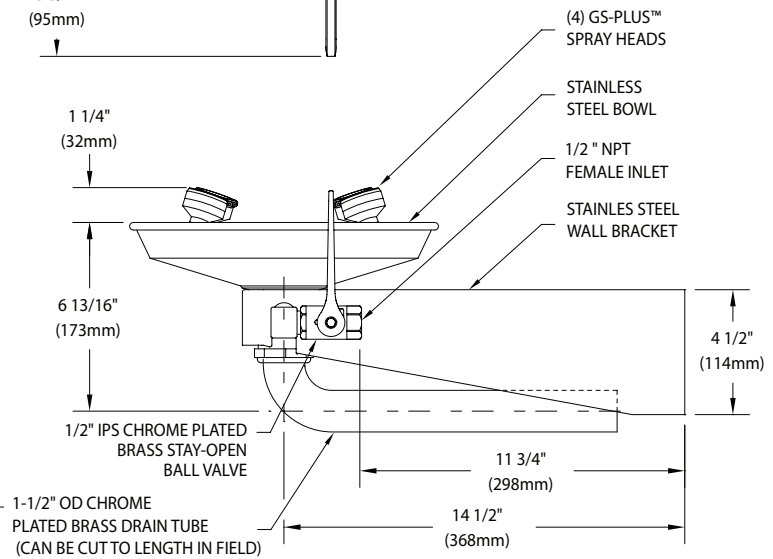
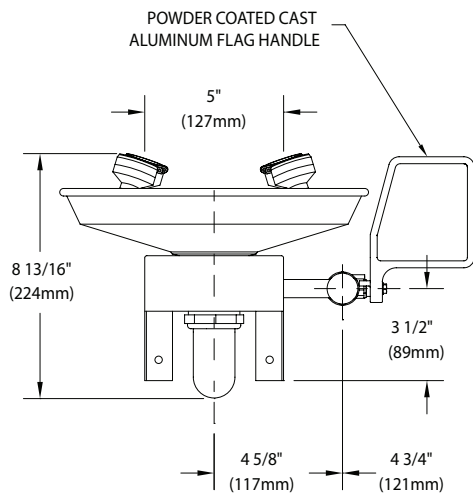
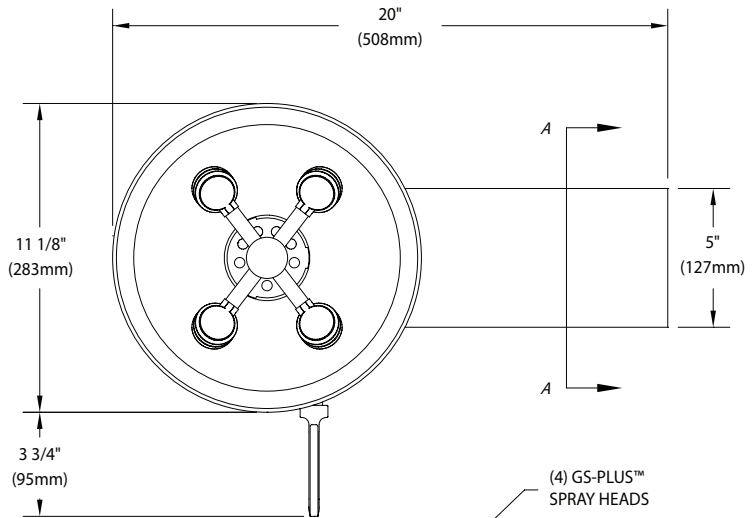
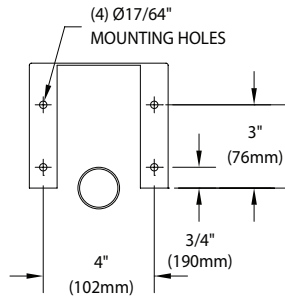

**NOTES:**

1. EACH GS-PLUS™ SPRAY HEAD HAS A "FLIP-TOP" DUST COVER, INTERNAL FLOW CONTROL AND FILTER TO REMOVE IMPURITIES FROM THE WATER FLOW.
2. UNIT SHOULD BE INSTALLED SO THAT SPRAY HEADS ARE NO MORE THAN 36" ABOVE FINISHED FLOOR.

Rev. 040119

THIS SPACE FOR ARCHITECT/ENGINEER APPROVAL

Sign Included



Due to continuing product improvement, the information contained in this document is subject to change without notice. All dimensions are  $\pm 1/4$ " (6mm). rev. 051319

