



□ **G1750BC** Eye/Face Wash, Wall Mounted, Stainless Steel Bowl and Cover



APPLICATION: Eye/face wash for wall mounting. Unit has stainless steel cover to protect bowl from dust, dirt and other contaminants. Two large FS-Plus™ spray-type outlet heads deliver a flood of water for rinsing eyes and face.

SPRAY HEAD ASSEMBLY: Two FS-Plus™ spray heads. Each head has an internal flow control and filter to remove impurities from the water flow.

VALVE: 1/2" IPS chrome plated brass stay-open ball valve. Valve is US-made with chrome plated brass ball and Teflon® seals.

BOWL: 11 1/2" stainless steel bowl with cover. Cover is raised automatically when flag handle is activated. Cover closes when handle is returned to closed position.

MOUNTING: Heavy duty cast aluminum wall bracket with powder coated finish.

SUPPLY: 1/2" NPT female inlet.

WASTE: 1 1/4" NPT female outlet.

SIGN: ANSI-compliant identification sign.

QUALITY ASSURANCE: Unit is completely assembled and water tested prior to shipment.

Available Options

- **HS** Auxiliary hand-held drench hose for rinsing eyes, face or body.
- **T** Chrome plated brass tailpiece and trap with 1 1/2" IPS waste connection.
- **TP** 1 1/2" OD chrome plated brass tailpiece.
- **TMV** G3600 thermostatic mixing valve precisely blends hot and cold water to deliver warm (tepid) water as required by ANSI Z358.1-2009. Refer to "Tempering Units" section for complete technical and product selection information.





□ G1750BC Eye/Face Wash, Wall Mounted, Stainless Steel Bowl and Cover

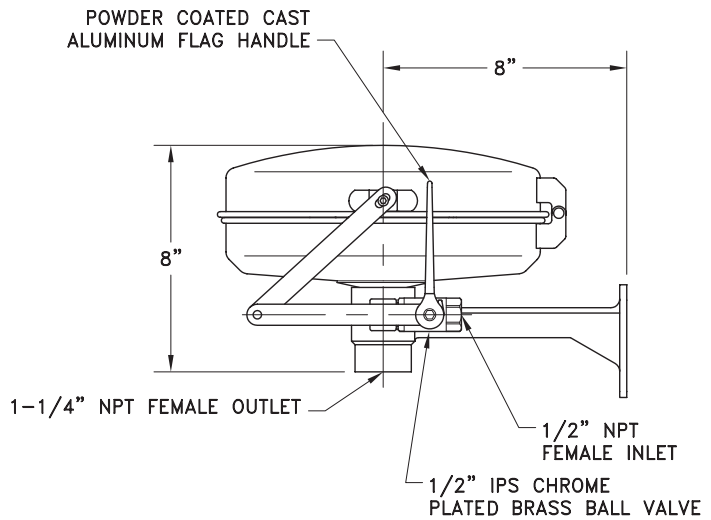
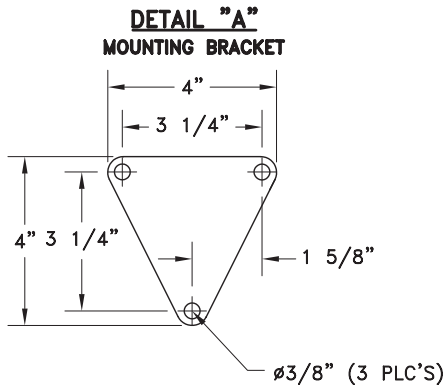
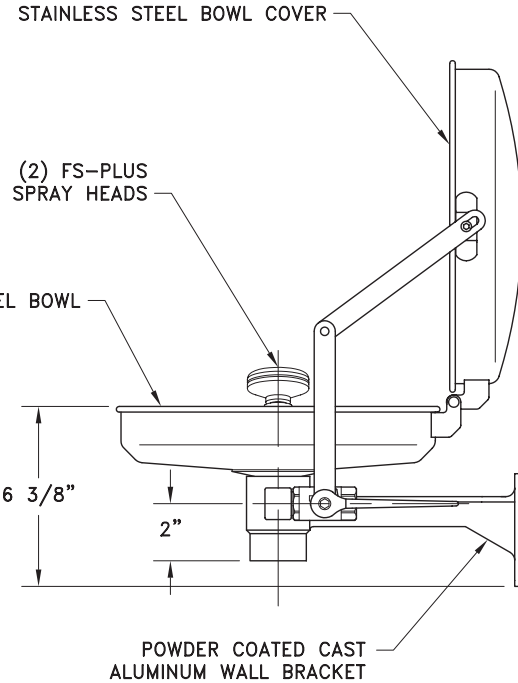
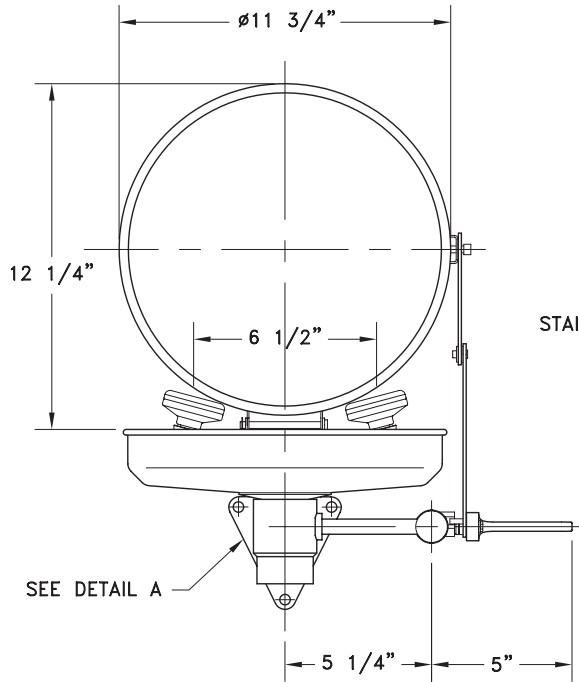

NOTE:
EACH FS-PLUS SPRAY HEAD HAS A "FLIP-TOP" DUST COVER, INTERNAL FLOW CONTROL AND FILTER TO REMOVE IMPURITIES FROM THE WATER FLOW.

THIS SPACE FOR ARCHITECT/ENGINEER APPROVAL

Due to continuing product improvement, the information contained in this document is subject to change without notice. All dimensions are $\pm 1/4$ " (6mm). rev. 0112

Sign Included

